



INSTITUT NATIONAL DE RECHERCHE EN INFORMATIQUE ET EN AUTOMATIQUE

Conditional stability for ill-posed elliptic Cauchy problems : the case of Lipschitz domains (part II)

Laurent Bourgeois — Jérémie Dardé

N° 6588

Septembre 2008

Thème NUM

*R*apport
de recherche

Conditional stability for ill-posed elliptic Cauchy problems : the case of Lipschitz domains (part *II*)

Laurent Bourgeois , Jérémie Dardé

Thème NUM — Systèmes numériques
Équipes-Projets Poems

Rapport de recherche n 6588 — Septembre 2008 — 26 pages

Abstract: This paper is devoted to a conditional stability estimate related to the ill-posed Cauchy problems for the Laplace's equation in domains with Lipschitz boundary. It completes the results obtained in [4] for domains of class $C^{1,1}$. This estimate is established by using an interior Carleman estimate and a technique based on a sequence of balls which approach the boundary. This technique is inspired from [2]. We obtain a logarithmic stability estimate, the exponent of which is specified as a function of the boundary's singularity. Such stability estimate induces a convergence rate for the method of quasi-reversibility introduced in [10] to solve the Cauchy problems. The optimality of this convergence rate is tested numerically, precisely a discretized method of quasi-reversibility is performed by using a nonconforming finite element. The obtained results show very good agreement between theoretical and numerical convergence rates.

Key-words: ill-posed problem, conditional stability, Carleman estimate, quasi-reversibility, singular boundary

Stabilité conditionnelle pour les problèmes de Cauchy elliptiques mal posés : le cas d'un domaine Lipschitzien (partie II)

Résumé : Ce document concerne une estimation de stabilité conditionnelle relative aux problèmes de Cauchy mal posés pour l'équation de Laplace dans un domaine Lipschitzien. Il complète les résultats obtenus dans [4] pour les domaines à bord $C^{1,1}$. Cette estimation est établie en utilisant une inégalité de Carleman à l'intérieur et une technique basée sur une suite de boules approchant le bord. Cette technique est inspirée de [2]. Nous obtenons une inégalité de stabilité logarithmique, dont l'exposant est précisée en fonction de la singularité du bord. Une telle inégalité de stabilité implique une vitesse de convergence pour la méthode de quasi-réversibilité introduite dans [10] pour résoudre les problèmes de Cauchy. L'optimalité de cette vitesse de convergence est testée numériquement, précisément une discrétisation de la méthode de quasi-réversibilité basée sur un élément fini non conforme est mise en oeuvre. Les résultats obtenus attestent un très bon accord entre les vitesses de convergence théoriques et numériques.

Mots-clés : problème mal posé, stabilité conditionnelle, inégalité de Carleman, quasi-réversibilité, bord singulier

1 Introduction

The problem of stability for ill-posed elliptic Cauchy problems is already discussed in [4] and we refer to the introduction of this paper for a general presentation of the problem and some bibliography. In [4], the following conditional stability result was obtained in the case of operator $P = -\Delta - k \cdot$, with $k \in \mathbb{R}$. For a bounded and connected open domain $\Omega \subset \mathbb{R}^N$ with $C^{1,1}$ boundary, if Γ_0 is an open part of $\partial\Omega$, then for all $\kappa \in]0, 1[$ there exists C such that for all functions $u \in H^2(\Omega)$ which satisfy

$$\|u\|_{H^2(\Omega)} \leq M, \quad \|Pu\|_{L^2(\Omega)} + \|u\|_{H^1(\Gamma_0)} + \|\partial_n u\|_{L^2(\Gamma_0)} \leq \delta,$$

for some constant M and sufficiently small δ ,

$$\|u\|_{H^1(\Omega)} \leq C \frac{M}{(\log(M/\delta))^\kappa}.$$

Furthermore, the upper bound $\kappa = 1$ of the exponent cannot be improved.

The result obtained in [4] is a generalization of the one obtained in [12] for domains with C^∞ boundary. The proof mainly relies on a Carleman estimate near the boundary, in which the weight function is expressed in term of the distance to the boundary. Since we have to differentiate twice this weight function, we need the boundary $\partial\Omega$ to be at least $C^{1,1}$. In the following paper, we now study how such a conditional stability result can be extended to Lipschitz domains, the boundary of which is not smooth enough to apply the same method.

We hence consider an open, bounded and connected domain $\Omega \subset \mathbb{R}^N$ the boundary $\partial\Omega$ of which is Lipschitz. In particular, this implies that Ω satisfies the cone property, and we denote by θ the angle value of such cone, $\theta \in]0, \pi/2[$. For sake of self-consistency, we say that Ω satisfies the cone property if there exist $\theta \in]0, \pi/2[$ and $R_0 > 0$ such that for all $x_0 \in \partial\Omega$, there exists $\xi \in \mathbb{R}^N$, $|\xi| = 1$, such that the finite cone

$$C = \{x \in \mathbb{R}^N, (x - x_0) \cdot \xi > |x - x_0| \cos \theta, |x - x_0| < R_0\}$$

is included in Ω .

As above, Γ_0 denotes an open part of $\partial\Omega$ which is $C^{1,1}$. Lastly, we assume that k is not an eigenvalue of the Dirichlet problem for the operator $-\Delta$ in Ω . The main result we obtain is that for all $\alpha \in [0, 1]$, for all $\kappa \in]0, (1 + \alpha)\kappa_0(\theta)/2[$ there exists C such that for all functions $u \in C^{1,\alpha}(\bar{\Omega})$ such that $\Delta u \in L^2(\Omega)$ and

$$\|u\|_{C^{1,\alpha}(\bar{\Omega})} \leq M, \quad \|Pu\|_{L^2(\Omega)} + \|u\|_{H^1(\Gamma_0)} + \|\partial_n u\|_{L^2(\Gamma_0)} \leq \delta,$$

for some constant M and sufficiently small δ , then

$$\|u\|_{H^1(\Omega)} \leq C \frac{M}{(\log(M/\delta))^\kappa}. \quad (1)$$

Here, $\kappa_0(\theta)$ is the solution of the following simple maximization problem

$$\kappa_0(\theta) = \frac{1}{2} \sup_{x>0} \frac{\sin \theta (1 - e^{-x})}{\sqrt{1+x} - \sin \theta}.$$

The continuous function κ_0 is increasing on the segment $[0, \pi/2]$ and ranges from $\kappa_0(0) = 0$ to $\kappa_0(\pi/2) = 1$. Since a domain of class C^1 has a Lipschitz

boundary which satisfies the cone property with any $\theta \in]0, \pi/2[$, we obtain that (1) is satisfied for all $\kappa \in]0, (1 + \alpha)/2[$ in that case. The analysis of the conditional stability in Lipschitz domains was already addressed in [2] and [13], but in these works, the exponent in front of the logarithm was not specified. This is the main novelty of the following paper to specify the exponent as a function of the geometric singularity. It is obtained by using of sequence of three spheres inequalities, the sequence of centers of these spheres approaching the boundary, and the sequence of radii tending to 0. This technique is borrowed from [2], with two differences. First, the three spheres inequalities result from Carleman estimates instead of doubling properties. Second, we perform an optimization of this sequence of inequalities in order to obtain the best possible logarithmic exponent.

Another concern is to obtain a convergence rate for the method of quasi-reversibility to solve the ill-posed Cauchy problems for the operator P . This requires a stability estimate for functions that are only in $H^2(\Omega)$. For $N = 2$, we obtain that for all $\kappa \in]0, \kappa_0(\theta)/2[$ there exists C such that for all functions $u \in H^2(\Omega)$ which satisfy

$$\|u\|_{H^2(\Omega)} \leq M, \quad \|Pu\|_{L^2(\Omega)} + \|u\|_{H^1(\Gamma_0)} + \|\partial_n u\|_{L^2(\Gamma_0)} \leq \delta,$$

for some constant M and sufficiently small δ , then

$$\|u\|_{H^1(\Omega)} \leq C \frac{M}{(\log(M/\delta))^\kappa}.$$

For $N = 3$, we have the same result for all $\kappa \in]0, \kappa_0(\theta)/4[$. As a consequence, we prove a logarithmic convergence rate for the method of quasi-reversibility, with the limit exponent $\kappa_0(\theta)/2$ in $2D$ and $\kappa_0(\theta)/4$ in $3D$, possibly $\kappa_0(\theta)$ provided we assume additional regularity for the solution of quasi-reversibility and the "true" solution.

From a numerical point of view, a connected question is to determine if the influence of the geometric singularity on the logarithmic exponent can be actually observed in numerical experiments. An easy way to test this is to capture the convergence rate of a discretized method of quasi-reversibility for a fixed refined mesh, when the regularization parameter tends to 0. In 2D, we analyze this convergence rate as a function of the smallest angle of a polygonal domain, and observe a pretty good agreement between numerical and theoretical convergence rates.

The paper is organized as follows. In section 2 we establish some preliminary useful results related to the three spheres inequality. The section 3 is devoted to the estimate up to the Lipschitz boundary, which leads to the main result of conditional stability in Ω . Lastly, in section 4, we derive from this conditional stability some convergence rate for the method of quasi-reversibility in Lipschitz domains. It enables one to compare such convergence rate with the convergence rate obtained numerically by using a discretized method of quasi-reversibility, and hence to test the optimality of our stability estimate.

2 Some preliminary results

This section consists of several lemmas that will be used in next section. They concern the three spheres inequality. We first recall the following interior Carleman estimate.

Lemma 1 : *We consider the operator $P = -\Delta - ak$, with $a, k \in \mathbb{R}$, $a \in]0, 1[$. Let ω, U denote two bounded and open domains with $\bar{\omega} \subset U \subset \mathbb{R}^N$. Let ϕ be a smooth function defined in U such that $\nabla\phi$ does not vanish in U . Let denote $P_\phi = h^2 e^{\frac{\phi}{h}} \circ P \circ e^{-\frac{\phi}{h}}$, and $p_\phi(x, \xi)$ the principal part of operator P_ϕ . We assume that*

$$\exists c_1 > 0, \quad p_\phi(x, \xi) = 0 \quad \text{and} \quad (x, \xi) \in U \times \mathbb{R}^N \quad \Rightarrow \quad \{\text{Rep}_\phi, \text{Imp}_\phi\}(x, \xi) \geq c_1. \quad (2)$$

Then there exist $K, h_0 > 0$, with K independent of ak , with h_0 depending on ak only through $|k|$, such that $\forall h \in]0, h_0[$, we have

$$\int_{\omega} u^2 e^{2\frac{\phi}{h}} dx + h^2 \int_{\omega} |\nabla u|^2 e^{2\frac{\phi}{h}} dx \leq Kh^3 \int_{\omega} |Pu|^2 e^{2\frac{\phi}{h}} dx, \quad (3)$$

for all function $u \in H_0^1(\omega, \Delta)$, where $H_0^1(\omega, \Delta)$ is the closure of $C_0^\infty(\omega)$ in $H^1(\omega, \Delta) = \{u \in H^1(\omega), \Delta u \in L^2(\omega)\}$.

Proof : The inequality (3) is obtained in [6] for $k = 0$, that is in the case of the Laplace operator $-\Delta$. Since p_ϕ does not depend on ak , there exist $K, h_0 > 0$, such that $\forall h \in]0, h_0[$, we have for all functions $u \in H_0^1(\omega, \Delta)$

$$\int_{\omega} u^2 e^{2\frac{\phi}{h}} dx + h^2 \int_{\omega} |\nabla u|^2 e^{2\frac{\phi}{h}} dx \leq Kh^3 \int_{\omega} |Pu + aku|^2 e^{2\frac{\phi}{h}} dx.$$

Since $|Pu + aku|^2 \leq 2(|Pu|^2 + k^2 u^2)$, if we assume that in addition h satisfies $2Kk^2 h^3 < 1/2$, we obtain (3) provided we replace K by $4K$ in the right-hand side of the inequality. ■

A short calculation shows that

$$\text{Rep}_\phi = |\xi|^2 - |\nabla\phi|^2, \quad \text{Imp}_\phi = 2\xi \cdot \nabla\phi$$

and

$$\{\text{Rep}_\phi, \text{Imp}_\phi\} = 4 \sum_{j=1}^n \nabla \left(\frac{\partial\phi}{\partial x_j} \right) \cdot \left(\xi_j \xi + \frac{\partial\phi}{\partial x_j} \nabla\phi \right).$$

One considers now a smooth function ψ defined on \bar{U} such that $\nabla\psi \neq 0$ on \bar{U} , and for $\alpha > 0$, $\phi(x) = e^{\alpha\psi(x)}$. We obtain

$$\{\text{Rep}_\phi, \text{Imp}_\phi\} = 4\alpha\phi \left(\xi^t \cdot \nabla^2\psi \cdot \xi + \alpha^2 \phi^2 (\nabla^t\psi \cdot \nabla^2\psi \cdot \nabla\psi) + \alpha(\xi \cdot \nabla\psi)^2 + \alpha^3 \phi^2 |\nabla\psi|^4 \right),$$

whence by denoting $\mu_0(x)$ the smallest eigenvalue of $\nabla^2\psi(x)$,

$$\{\text{Rep}_\phi, \text{Imp}_\phi\} \geq 4\alpha\phi \left(\mu_0(|\xi|^2 + \alpha^2 \phi^2 |\nabla\psi|^2) + \alpha(\xi \cdot \nabla\psi)^2 + \alpha^3 \phi^2 |\nabla\psi|^4 \right).$$

For $p_\phi(x, \xi) = 0$, we have

$$|\xi|^2 = \alpha^2 \phi^2 |\nabla\psi|^2, \quad \xi \cdot \nabla\psi = 0,$$

whence

$$\{\text{Rep}_\phi, \text{Imp}_\phi\} \geq 4\alpha^3 \phi^3 |\nabla \psi|^2 (2\mu_0 + \alpha |\nabla \psi|^2).$$

In we define

$$m_0 := \inf_{x \in \bar{U}} \mu_0(x), \quad c_0 := \inf_{x \in \bar{U}} |\nabla \psi|^2,$$

and if $m_0 < 0$, we have $\{\text{Rep}_\phi, \text{Imp}_\phi\} \geq c_1 > 0$ on $U \times \mathbb{R}^N$ when $p_\phi(x, \xi) = 0$ for

$$\alpha > -2 \frac{m_0}{c_0}.$$

We consider now the particular domain $\omega = B(R_1, R_2) := \{x \in \mathbb{R}^N, R_1 < |x - q| < R_2\}$ with $q \in \mathbb{R}^N$, and the function $\psi(x) = -|x - q|^2$. We can take $U = B(q, R_1 - \varepsilon, R_2 + \varepsilon)$ for small $\varepsilon > 0$. We obtain $m_0 = -2$ and $c_0 = 4(R_1 - \varepsilon)^2$, and finally assumption (2) holds as soon as $\alpha > 1/R_1^2$.

We now apply lemma 1 and lemma 3 in [4] to obtain a so-called three spheres inequality. The proof of such inequality is classical (see [11, 12]), but it is reproduced here in order to find how the constants involved in the inequality depend on some useful parameters.

Lemma 2 : *We consider the operator $P = -\Delta - ak$. with $a, k \in \mathbb{R}$ and $a \in]0, 1[$. Let $q \in \Omega$, and let $0 < r_0 < r_1 < r_2 < r_3 < r_4 < r_5 < r_6$ such that $B(q, r_6) \subset \Omega$. If α satisfies $\alpha r_0^2 > 1$, then there exists a constant C , which depends on ak only through $|k|$, such that we have for all $u \in H^1(\Omega, \Delta)$,*

$$\|u\|_{H^1(B(q, r_3))} \leq C \left(\|Pu\|_{L^2(B(q, r_6))} + \|u\|_{H^1(B(q, r_2))} \right)^{\frac{s}{s+1}} \|u\|_{H^1(B(q, r_6))}^{\frac{1}{s+1}}, \quad (4)$$

with

$$s = \frac{g(r_3) - g(r_4)}{g(r_1) - g(r_3)}, \quad g(r) = e^{-\alpha r^2}.$$

Proof : One applies lemma 1 in the domain $\omega = B(r_0, r_6)$ for $\phi = e^{\alpha \psi}$ with $\psi(x) = -|x - q|^2$. We have seen that assumption (2) is satisfied as soon as $\alpha r_0^2 > 1$. Assuming that this inequality holds, we obtain there exists $K, h_0 > 0$ such that for $0 < h < h_0$ (K does not depend on ak , h_0 depends on ak only through $|k|$),

$$\int_{\omega} (|v|^2 + |\nabla v|^2) e^{2\frac{\phi}{h}} dx \leq K \int_{\omega} |Pv|^2 e^{2\frac{\phi}{h}} dx, \quad (5)$$

for all functions $v \in H_0^1(\omega, \Delta)$.

Now we take $u \in H^1(\Omega, \Delta)$ and $v = \chi u \in H_0^1(\omega, \Delta)$, where χ is a C^∞ cut-off function such that $\chi \in [0, 1]$ and

$$\begin{cases} \chi = 0 & \text{in } \overline{B(r_0, r_1)} \cup \overline{B(r_5, r_6)} \\ \chi = 1 & \text{in } \overline{B(r_2, r_4)}. \end{cases}$$

In the following we denote $g(r) = e^{-\alpha r^2}$. Hence g is a non increasing function.

$$\int_{\omega} (|v|^2 + |\nabla v|^2) e^{2\frac{\phi}{h}} dx \geq e^{2\frac{g(r_3)}{h}} \int_{B(r_2, r_3)} (|u|^2 + |\nabla u|^2) dx,$$

and

$$\begin{aligned} \int_{\omega} |Pv|^2 e^{2\frac{\phi}{h}} dx &= \int_{B(r_2, r_4)} |Pu|^2 e^{2\frac{\phi}{h}} dx + \int_{B(r_1, r_2)} |P(\chi u)|^2 e^{2\frac{\phi}{h}} dx \\ &\quad + \int_{B(r_4, r_5)} |P(\chi u)|^2 e^{2\frac{\phi}{h}} dx. \end{aligned}$$

Since we have $P(\chi u) = \chi(Pu) - 2\nabla\chi \cdot \nabla u - (\Delta\chi)u$, we obtain the following estimates (K is a constant which depends only on χ) :

$$\begin{aligned} \int_{B(r_2, r_4)} |Pu|^2 e^{2\frac{\phi}{h}} dx &\leq e^{2\frac{g(r_2)}{h}} \int_{B(r_2, r_4)} |Pu|^2 dx, \\ \int_{B(r_1, r_2)} |P(\chi u)|^2 e^{2\frac{\phi}{h}} dx &\leq e^{2\frac{g(r_1)}{h}} \int_{B(r_1, r_2)} |Pu|^2 dx + K e^{2\frac{g(r_1)}{h}} \int_{B(r_1, r_2)} (|u|^2 + |\nabla u|^2) dx, \\ \int_{B(r_4, r_5)} |P(\chi u)|^2 e^{2\frac{\phi}{h}} dx &\leq e^{2\frac{g(r_4)}{h}} \int_{B(r_4, r_5)} |Pu|^2 dx + K e^{2\frac{g(r_4)}{h}} \int_{B(r_4, r_5)} (|u|^2 + |\nabla u|^2) dx. \end{aligned}$$

Gathering the above inequalities, it follows that

$$\begin{aligned} \int_{\omega} |Pv|^2 e^{2\frac{\phi}{h}} dx &\leq K_1 e^{2\frac{g(r_1)}{h}} \left(\int_{B(q, r_6)} |Pu|^2 dx + \int_{B(q, r_2)} (|u|^2 + |\nabla u|^2) dx \right) \\ &\quad + K_2 e^{2\frac{g(r_4)}{h}} \int_{B(q, r_6)} (|u|^2 + |\nabla u|^2) dx, \end{aligned}$$

where K_1 and K_2 are two constants which are independent of ak .

Finally, the inequality (5) implies

$$\begin{aligned} e^{2\frac{g(r_3)}{h}} \|u\|_{H^1(B(r_2, r_3))}^2 &\leq K_1 e^{2\frac{g(r_1)}{h}} \left(\|Pu\|_{L^2(B(q, r_6))}^2 + \|u\|_{H^1(B(q, r_2))}^2 \right) \\ &\quad + K_2 e^{2\frac{g(r_4)}{h}} \|u\|_{H^1(B(q, r_6))}^2. \end{aligned}$$

Using

$$\|u\|_{H^1(B(q, r_3))}^2 = \|u\|_{H^1(B(q, r_2))}^2 + \|u\|_{H^1(B(r_2, r_3))}^2,$$

We obtain

$$\begin{aligned} e^{2\frac{g(r_3)}{h}} \|u\|_{H^1(B(q, r_3))}^2 &\leq K_1 e^{2\frac{g(r_1)}{h}} \left(\|Pu\|_{L^2(B(q, r_6))}^2 + \|u\|_{H^1(B(q, r_2))}^2 \right) \\ &\quad + K_2 e^{2\frac{g(r_4)}{h}} \|u\|_{H^1(B(q, r_6))}^2. \end{aligned}$$

Denoting $k_1 = g(r_1) - g(r_3) > 0$ and $k_2 = g(r_3) - g(r_4) > 0$, we obtain

$$\|u\|_{H^1(B(q, r_3))} \leq K_1 e^{\frac{k_1}{h}} \left(\|Pu\|_{L^2(B(q, r_6))} + \|u\|_{H^1(B(q, r_2))} \right) + K_2 e^{-\frac{k_2}{h}} \|u\|_{H^1(B(q, r_6))}.$$

Let $s > 0$ and $c > 0$ such that

$$\frac{c}{\varepsilon} = K_1 e^{\frac{k_1}{h}}, \quad \varepsilon^s = K_2 e^{-\frac{k_2}{h}}.$$

A simple calculation proves that

$$s = \frac{k_2}{k_1} = \frac{g(r_3) - g(r_4)}{g(r_1) - g(r_3)}, \quad c = K_1 (K_2)^{(k_1/k_2)},$$

and we obtain for all $u \in H^1(\Omega, \Delta)$, for all $\varepsilon \in]0, \varepsilon_0[$ with

$$\varepsilon_0 = K_2^{(k_1/k_2)} e^{-\frac{k_1}{h_0}},$$

the inequality

$$\|u\|_{H^1(B(q, r_3))} \leq \frac{c}{\varepsilon} (\|P_k u\|_{L^2(B(q, r_6))} + \|u\|_{H^1(B(q, r_2))}) + \varepsilon^s \|u\|_{H^1(B(q, r_6))}.$$

The constant c does not depend on ak , ε_0 depends on ak only through $|k|$. It remains to apply lemma 3 in [4], since $\|u\|_{H^1(B(q, r_3))} \leq \|u\|_{H^1(B(q, r_6))}$. ■

Lemma 3 : Let us denote P_k the operator $-\Delta \cdot -k \cdot$, with $k \in \mathbb{R}$. Let $\tilde{q} \in \Omega$, and let $0 < \tilde{r}_0 < \tilde{r}_1 < \tilde{r}_2 < \tilde{r}_3 < \tilde{r}_4 < \tilde{r}_5 < \tilde{r}_6$ such that $B(\tilde{q}, \tilde{r}_6) \subset \Omega$. Consider now $q \in \Omega$ and for $\mu \in]0, 1[$, $r_i = \mu \tilde{r}_i$ ($i = 1, 2, \dots, 6$), with $B(q, r_6) \subset \Omega$.

We assume that the three spheres inequality (4) associated to the operator $P_{\mu^2 k}$ and the sequence of balls $B(\tilde{q}, \tilde{r}_i)$ is satisfied with the constants \tilde{C} and s . Then the three spheres inequality (4) associated to the operator P_k and the sequence of balls $B(q, r_i)$ is satisfied with the constants $C = \tilde{C}/\mu$ and s .

Proof : The proof relies on the change of variables $x - q = \mu(\tilde{x} - \tilde{q})$. We define the function \tilde{u} as $\tilde{u}(\tilde{x}) = u(x) = \tilde{u}(\tilde{q} + (x - q)/\mu)$.

We obtain

$$\int_{B(q, r_i)} |u(x)|^2 + |\nabla u(x)|^2 dx = \mu^N \left(\int_{B(\tilde{q}, \tilde{r}_i)} |\tilde{u}(\tilde{x})|^2 + \frac{1}{\mu^2} |\nabla \tilde{u}(\tilde{x})|^2 d\tilde{x} \right),$$

whence

$$\mu^{\frac{N}{2}} \|\tilde{u}\|_{H^1(B(\tilde{q}, \tilde{r}_i))} \leq \|u\|_{H^1(B(q, r_i))} \leq \mu^{\frac{N}{2}-1} \|\tilde{u}\|_{H^1(B(\tilde{q}, \tilde{r}_i))}.$$

Similarly, we obtain

$$\|P_k u\|_{L^2(B(q, r_i))} = \mu^{\frac{N}{2}-2} \|P_{\mu^2 k} \tilde{u}\|_{L^2(B(\tilde{q}, \tilde{r}_i))}.$$

By using the three spheres inequality (4) associated to the balls $B(\tilde{q}, \tilde{r}_i)$ for operator $P_{\mu^2 k}$, we obtain

$$\begin{aligned} \|u\|_{H^1(B(q, r_3))} &\leq \mu^{\frac{N}{2}-1} \|\tilde{u}\|_{H^1(B(\tilde{q}, \tilde{r}_3))} \\ &\leq \tilde{C} \mu^{\frac{N}{2}-1} (\|P_{\mu^2 k} \tilde{u}\|_{L^2(B(\tilde{q}, \tilde{r}_6))} + \|\tilde{u}\|_{H^1(B(\tilde{q}, \tilde{r}_2))})^{\frac{s}{s+1}} \|\tilde{u}\|_{H^1(B(\tilde{q}, \tilde{r}_6))}^{\frac{1}{s+1}} \\ &\leq \tilde{C} \mu^{\frac{N}{2}-1} \left(\frac{1}{\mu^{\frac{N}{2}-2}} \|P_k u\|_{L^2(B(q, r_6))} + \frac{1}{\mu^{\frac{N}{2}}} \|u\|_{H^1(B(q, r_2))} \right)^{\frac{s}{s+1}} \left(\frac{1}{\mu^{\frac{N}{2}}} \|u\|_{H^1(B(q, r_6))} \right)^{\frac{1}{s+1}} \\ &\leq \frac{\tilde{C}}{\mu} (\|P_k u\|_{L^2(B(q, r_6))} + \|u\|_{H^1(B(q, r_2))})^{\frac{s}{s+1}} \|u\|_{H^1(B(q, r_6))}^{\frac{1}{s+1}}, \end{aligned}$$

which completes the proof. ■

3 The main theorem

Our main theorem is based on the following proposition, which is similar to proposition 4 in [4]. It concerns the propagation of data from the interior of the domain up the boundary of such domain. However, it should be noted that in proposition 4 of [4], we estimated the H^1 norm of the function in a neighborhood of a point $x_0 \in \partial\Omega$ with the help of the H^1 norm of the function in an open domain $\omega_1 \Subset \Omega$. Here, we estimate the value of the function and its first derivatives at x_0 with the help of the H^1 norm of the function in ω_1 . As a result, the regularity assumptions concerning the function u are not the same as in [4].

Proposition 1 : *There exists an open domain $\omega_1 \Subset \Omega$ such that for all $\alpha \in]0, 1[$, for all $\kappa < \alpha\kappa_0(\theta)$ and $\kappa' < \kappa_0(\theta)$, with*

$$\kappa_0(\theta) = \frac{1}{2} \sup_{x>0} \frac{\sin \theta(1 - e^{-x})}{\sqrt{1+x} - \sin \theta}, \quad (6)$$

there exists $c > 0$ such that for sufficiently small ε , for all $u \in C^{1,\alpha}(\overline{\Omega})$ with $\Delta u \in L^2(\Omega)$,

$$\|u\|_{C^1(\partial\Omega)} \leq e^{c/\varepsilon} (\|Pu\|_{L^2(\Omega)} + \|u\|_{H^1(\omega_1)}) + \varepsilon^\kappa \|u\|_{C^{1,\alpha}(\overline{\Omega})},$$

$$\|u\|_{C^0(\partial\Omega)} \leq e^{c/\varepsilon} (\|Pu\|_{L^2(\Omega)} + \|u\|_{H^1(\omega_1)}) + \varepsilon^{\kappa'} \|u\|_{C^{1,\alpha}(\overline{\Omega})}.$$

The second inequality holds also in the case $\alpha = 0$.

In order to obtain proposition 1, we need the two following lemmas. The first one is a minor generalization of the lemma proved in [11] in the particular case $\mu = 1$, while the second one is the counterpart of lemma 3 in [4].

Lemma 4 : *Let $\beta_n > 0$ satisfy for $n \in \mathbb{N}$,*

$$\beta_{n+1} \leq \frac{1}{\mu^n} (\beta_n + A)^\nu B^{1-\nu},$$

with $A > 0$, $B > 0$, $\nu \in]0, 1[$, $\mu \in]0, 1[$ and $\beta_n \leq B$. Then one has for $n \in \mathbb{N}^*$

$$\beta_n \leq \frac{2^{\frac{1}{1-\nu}}}{\mu^{\frac{n-1}{1-\nu}}} (\beta_0 + A)^{\nu^n} B^{1-\nu^n}.$$

Proof : If $B < \beta_0 + A$, the proof is complete. If $\beta_0 + A \leq B$, in particular $A \leq B$, we have

$$\frac{\beta_{n+1}}{B} \leq \frac{1}{\mu^n} \left(\frac{\beta_n + A}{B} \right)^\nu$$

and

$$\frac{A}{B} \leq \frac{1}{\mu^n} \left(\frac{A}{B} \right)^\nu \leq \frac{1}{\mu^n} \left(\frac{\beta_n + A}{B} \right)^\nu.$$

From the two above inequalities, it follows that

$$\frac{\beta_{n+1} + A}{2^{\frac{1}{1-\nu}} B} \leq \frac{1}{\mu^n} \left(\frac{\beta_n + A}{2^{\frac{1}{1-\nu}} B} \right)^\nu,$$

that is

$$x_{n+1} \leq \frac{x_n^\nu}{\mu^n}, \quad x_n := \frac{\beta_n + A}{2^{\frac{1}{1-\nu}} B}.$$

By iterating the above inequality, we obtain

$$\begin{aligned} x_n &\leq \left(\frac{1}{\mu}\right)^{n-1+(n-2)\nu+(n-3)\nu^2+\dots+\nu^{n-2}} x_0^{\nu^n} \\ &\leq \left(\frac{1}{\mu}\right)^{(n-1)(1+\nu+\nu^2+\dots+\nu^{n-2})} x_0^{\nu^n} \leq \left(\frac{1}{\mu}\right)^{\frac{n-1}{1-\nu}} x_0^{\nu^n}, \end{aligned}$$

whence

$$\beta_n \leq \frac{2^{\frac{1}{1-\nu}}}{\mu^{\frac{n-1}{1-\nu}}} (\beta_0 + A) \nu^n B^{1-\nu^n},$$

which completes the proof. ■

Lemma 5 : Let C , β , A and B denote four non negative reals and $\nu \in]0, 1[$ such that

$$\beta \leq C A^\nu B^{1-\nu}.$$

Then $\forall \varepsilon > 0$,

$$\beta \leq \frac{c}{\varepsilon} A + \varepsilon^s B,$$

with

$$s = \frac{\nu}{1-\nu}, \quad c = \left(\frac{C}{s^{1/(s+1)} + s^{-s/(s+1)}}\right)^{\frac{s+1}{s}}.$$

Proof : For $c, s > 0$ as defined in the statement of the lemma, the minimum of the function f defined for $\varepsilon > 0$ by

$$f(\varepsilon) = \frac{c}{\varepsilon} A + \varepsilon^s B$$

is $C A^\nu B^{1-\nu}$, which completes the proof. ■

Proof of proposition 1 : The proof is divided into three parts. In the first step of the proof we follow the technique of [2], which consists in defining a sequence of balls the radii of which is decreasing and the center of which is approaching the boundary of the domain. Since Ω satisfies the cone property (see our definition in the introduction), there exist $R_0 > 0$, $\theta \in]0, \pi/2[$ with R_0 and θ independent of $x_0 \in \partial\Omega$, and $\xi \in \mathbb{R}^N$ with $|\xi| = 1$ such that the finite cone

$$C = \{x, |x - x_0| < R_0, (x - x_0) \cdot \xi > |x - x_0| \cos \theta\}$$

satisfies $C \subset \Omega$. We also denote

$$C' = \{x, |x - x_0| < R_0, (x - x_0) \cdot \xi > |x - x_0| \cos \theta'\},$$

with

$$\theta' = \arcsin(t \sin \theta), \tag{7}$$

where the coefficient $t \in]0, 1[$ will be specified further. It should be noted that definition (7) leads to $\theta' \in]0, \pi/2[$. We now denote $q_0 = x_0 + (R_0/2)\xi$, $d_0 =$

$|q_0 - x_0|$ and $\rho_0 = d_0 \sin \theta'$. We hence have $B(q_0, \rho_0) \in C'$. Let define the sequence of balls $B(q_n, \rho_n) \subset C'$ with $d_n = |q_n - x_0|$ and $\rho_n = d_n \sin \theta'$ by following induction :

$$\begin{cases} q_{n+1} = q_n - \alpha_n \xi \\ \rho_{n+1} = \mu \rho_n \\ d_{n+1} = \mu d_n, \end{cases} \quad (8)$$

where α_n and μ will be defined further. From the above equations, we deduce that

$$\alpha_n = (1 - \mu)d_n. \quad (9)$$

The objective is to use a three spheres inequality such as (4) for each n , the center of these three spheres being $q = q_n$. We hence define, for $n \in \mathbb{N}$, $0 < r_{0n} < r_{1n} < r_{2n} = \rho_n < r_{3n} < r_{4n} < r_{5n} < r_{6n}$ and $y_{in} = r_{in}/r_{0n} > 1$ for $i = 1, \dots, 6$. We assume that the y_{in} do not depend on n , that is $y_{in} := y_i$. We specify $t = r_{2n}/r_{6n} = y_2/y_6$ in (7), so that we have $B(q_n, r_{6n}) \in C \subset \Omega$ for all n (see figure 1).

On the other hand, if α_n is chosen such that

$$\rho_{n+1} + \alpha_n = r_{3n}, \quad (10)$$

we have $B(q_{n+1}, \rho_{n+1}) \subset B(q_n, r_{3n})$ since for $|x - q_{n+1}| < \rho_{n+1}$,

$$|x - q_n| \leq |x - q_{n+1}| + |q_{n+1} - q_n| < \rho_{n+1} + \alpha_n = r_{3n}.$$

The equations (9) and (10) uniquely define μ as

$$\mu = \frac{r_{6n} - r_{3n} \sin \theta}{r_{6n} - r_{2n} \sin \theta} = \frac{y_6 - y_3 \sin \theta}{y_6 - y_2 \sin \theta} \in]0, 1[.$$

By using the notation $P_k = -\Delta \cdot -k \cdot$, we now apply lemma 2 for operator $P_{\mu^{2n}k}$ and for the spheres of center q_0 and of radii r_{i0} , with α such that $\beta := \alpha r_{00}^2 > 1$. We thus obtain for $u \in H^1(\Omega, \Delta)$,

$$\|u\|_{H^1(B(q_0, r_{30}))} \leq C \left(\|P_{\mu^{2n}k} u\|_{L^2(B(q_0, r_{60}))} + \|u\|_{H^1(B(q_0, r_{20}))} \right)^{\frac{s}{s+1}} \|u\|_{H^1(B(q_0, r_{60}))}^{\frac{1}{s+1}},$$

with C independent of μ and n . With the help of lemma 3, and since $r_{in} = \mu^n r_{i0}$ for $i = 1, \dots, 6$, the three spheres inequality for the spheres of center q_n and of radii r_{in} is

$$\|u\|_{H^1(B(q_n, r_{3n}))} \leq \frac{C}{\mu^n} \left(\|P_k u\|_{L^2(B(q_n, r_{6n}))} + \|u\|_{H^1(B(q_n, r_{2n}))} \right)^{\frac{s}{s+1}} \|u\|_{H^1(B(q_n, r_{6n}))}^{\frac{1}{s+1}},$$

which implies that for all $u \in H^1(\Omega, \Delta)$,

$$\|u\|_{H^1(B(q_{n+1}, \rho_{n+1}))} \leq \frac{C}{\mu^n} \left(\|P u\|_{L^2(\Omega)} + \|u\|_{H^1(B(q_n, \rho_n))} \right)^{\frac{s}{s+1}} \|u\|_{H^1(\Omega)}^{\frac{1}{s+1}}.$$

It should be noted that in the above inequality, C and s are independent of n , in particular

$$s = \frac{e^{-\beta y_3^2} - e^{-\beta y_4^2}}{e^{-\beta y_1^2} - e^{-\beta y_3^2}}.$$

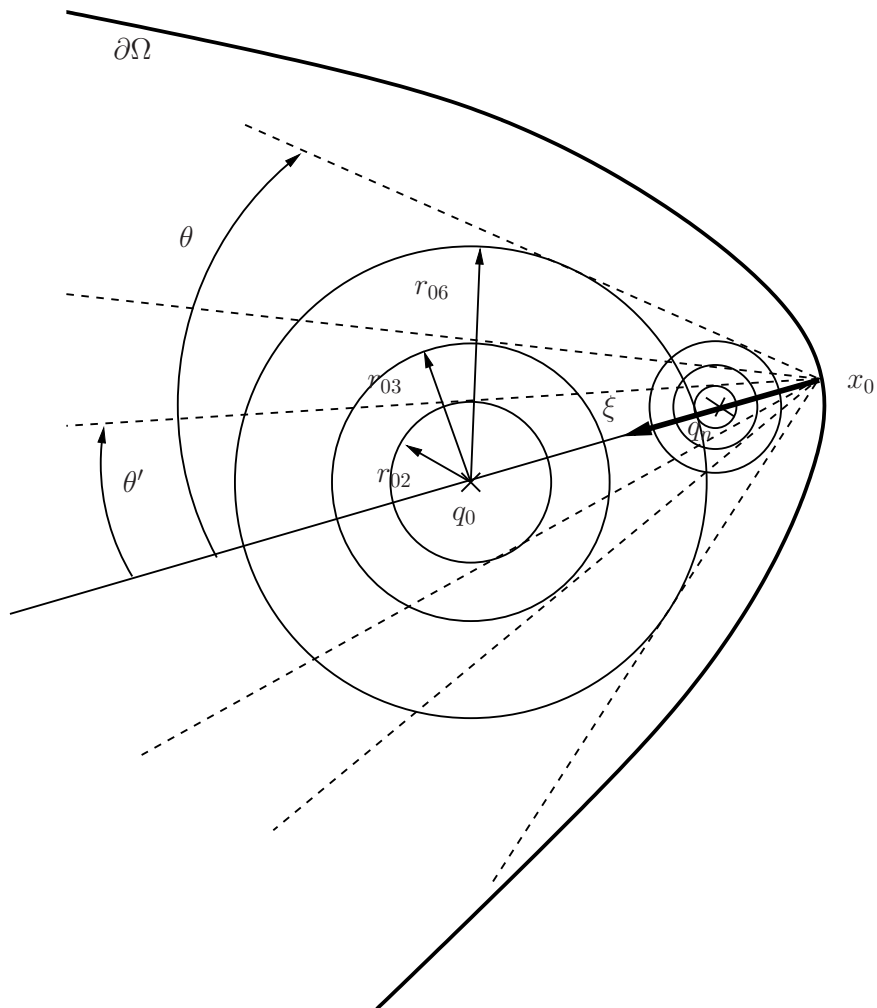

Figure 1: The sequence of three spheres inequalities

Without loss of generality we assume that $C \geq 1$, so that by denoting $C' = C^{s+1}$, $\|u\|_{H^1(B(q_{n+1}, \rho_{n+1}))} \leq C' \|u\|_{H^1(\Omega)}$, and we can apply lemma 4 with $\beta_n = \|u\|_{H^1(B(q_n, \rho_n))}$, $A = \|Pu\|_{L^2(\Omega)}$, $B = C' \|u\|_{H^1(\Omega)}$, $\nu = s/(s+1)$. We obtain

$$\|u\|_{H^1(B(q_n, \rho_n))} \leq \frac{2^{\frac{1}{1-\nu}}}{\mu^{\frac{n-1}{1-\nu}}} (\|Pu\|_{L^2(\Omega)} + \|u\|_{H^1(B(q_0, \rho_0))})^{\nu^n} (C' \|u\|_{H^1(\Omega)})^{1-\nu^n}.$$

We apply now lemma 5 and obtain $\forall \varepsilon > 0$,

$$\|u\|_{H^1(B(q_n, \rho_n))} \leq \frac{c_n}{\varepsilon} (\|Pu\|_{L^2(\Omega)} + \|u\|_{H^1(B(q_0, \rho_0))}) + \varepsilon^{s_n} C' \|u\|_{H^1(\Omega)}$$

with

$$s_n = \frac{\nu^n}{1 - \nu^n}, \quad c_n = \left(\frac{2^{\frac{1}{1-\nu}}}{\mu^{\frac{n-1}{1-\nu}}} \frac{1}{E(s_n)} \right)^{\frac{s_n+1}{s_n}},$$

and

$$E(s) := s^{1/(s+1)} + s^{-s/(s+1)}.$$

We notice that for $s > 0$, $E(s) > 1$, whence

$$\log \left(\frac{2^{\frac{1}{1-\nu}}}{\mu^{\frac{n-1}{1-\nu}}} \frac{1}{E(s_n)} \right) < \frac{1}{1-\nu} \log \left(\frac{2}{\mu^{n-1}} \right).$$

As a result,

$$0 < c_n < e^{\frac{1}{s_n} \frac{1}{(1-\nu)^2} \log \left(\frac{2}{\mu^{n-1}} \right)} = e^{\frac{c}{s_n} \log \left(\frac{2}{\mu^{n-1}} \right)},$$

for some constant $c > 0$. Here we have used the fact that $s_n + 1 < 1/(1-\nu)$. Since $s_n > \nu^n$, we finally obtain $\forall n \in \mathbb{N}^*$, $\forall \varepsilon > 0$ and $\forall u \in H^1(\Omega, \Delta)$,

$$\|u\|_{H^1(B(q_n, \rho_n))} \leq \frac{e^{\frac{c}{\nu^n} \log \left(\frac{2}{\mu^{n-1}} \right)}}{\varepsilon} (\|Pu\|_{L^2(\Omega)} + \|u\|_{H^1(B(q_0, \rho_0))}) + C' \varepsilon^{\nu^n} \|u\|_{H^1(\Omega)}. \quad (11)$$

The second step of the proof consists of estimating the C^1 norm of u on $\partial\Omega$ by using the estimate (11) for sufficiently large n and the regularity of u , which is $C^{1,\alpha}(\overline{\Omega})$, $\alpha \in]0, 1]$. We have $B(q_n, \rho_n) \subset B(x_0, \varepsilon')$ if and only if $d_n + \rho_n \leq \varepsilon'$, that is $\mu^n(d_0 + \rho_0) \leq \varepsilon'$. Let n_0 denote the smaller n which satisfies this inequality, that is

$$\frac{\log((d_0 + \rho_0)/\varepsilon')}{\log 1/\mu} \leq n_0 < \frac{\log((d_0 + \rho_0)/\varepsilon')}{\log 1/\mu} + 1.$$

For all $x \in B(q_{n_0}, \rho_{n_0})$, and for $v = u$ or $v = \partial u / \partial x_i$, $i = 1, \dots, N$, we have

$$|v(x_0)|^2 \leq 2|v(x)|^2 + 2\|u\|_{C^{1,\alpha}(\overline{\Omega})}^2 \varepsilon'^{2\alpha}. \quad (12)$$

After integration over $B(q_{n_0}, \rho_{n_0})$, we obtain by denoting

$$S_{x_0}(u) = \max(|u(x_0)|, \left| \frac{\partial u}{\partial x_1}(x_0) \right|, \dots, \left| \frac{\partial u}{\partial x_N}(x_0) \right|),$$

$$V_N \rho_{n_0}^N S_{x_0}^2(u) \leq 2\|u\|_{H^1(B(q_{n_0}, \rho_{n_0}))}^2 + 2V_N \rho_{n_0}^N \varepsilon'^{2\alpha} \|u\|_{C^{1,\alpha}(\overline{\Omega})}^2,$$

where V_N is the volume of the unit sphere in \mathbb{R}^N . Finally,

$$S_{x_0}(u) \leq \sqrt{\frac{2}{V_N \rho_{n_0}^N}} \|u\|_{H^1(B(q_{n_0}, \rho_{n_0}))} + \sqrt{2} \varepsilon'^\alpha \|u\|_{C^{1,\alpha}(\bar{\Omega})}. \quad (13)$$

From (11) with $n = n_0$ and (13), we obtain there exists $c, C > 0$ such that for all $\varepsilon, \varepsilon' > 0$,

$$\begin{aligned} S_{x_0}(u) &\leq C \frac{1}{\rho_{n_0}^{N/2}} \frac{e^{\frac{c}{\nu^{n_0}} \log\left(\frac{2}{\mu^{n_0-1}}\right)}}{\varepsilon} (\|Pu\|_{L^2(\Omega)} + \|u\|_{H^1(B(q_0, \rho_0))}) \\ &\quad + C \frac{1}{\rho_{n_0}^{N/2}} \varepsilon^{\nu^{n_0}} \|u\|_{H^1(\Omega)} + C \varepsilon'^\alpha \|u\|_{C^{1,\alpha}(\bar{\Omega})}. \end{aligned}$$

We have $\|u\|_{H^1(\Omega)} \leq c \|u\|_{C^{1,\alpha}(\bar{\Omega})}$ for some $c > 0$. Furthermore, $\mu^{n_0-1}(d_0 + \rho_0) > \varepsilon'$ and $\rho_{n_0} = \mu^{n_0} \rho_0$ lead to

$$\rho_{n_0} > \mu \frac{\rho_0}{d_0 + \rho_0} \varepsilon'.$$

We obtain there exists $c, C > 0$ such that for all $\varepsilon, \varepsilon' > 0$,

$$\begin{aligned} S_{x_0}(u) &\leq C \frac{1}{\varepsilon'^{N/2}} \frac{e^{\frac{c}{\nu^{n_0}} \log\left(\frac{2}{\mu^{n_0-1}}\right)}}{\varepsilon} (\|Pu\|_{L^2(\Omega)} + \|u\|_{H^1(B(q_0, \rho_0))}) \\ &\quad + C \left(\frac{\varepsilon^{\nu^{n_0}}}{\varepsilon'^{N/2}} + \varepsilon'^\alpha \right) \|u\|_{C^{1,\alpha}(\bar{\Omega})}. \end{aligned}$$

Now we introduce the relationship $\varepsilon^{\nu^{n_0}} / \varepsilon'^{\frac{N}{2}} = \varepsilon'^\alpha$, and since $\nu^{n_0} < 1$ we obtain a new constant $C > 0$ such that

$$S_{x_0}(u) \leq C \frac{e^{\frac{c}{\nu^{n_0}} \log\left(\frac{2}{\mu^{n_0-1}}\right)}}{\varepsilon'^{\frac{\alpha+N}{\nu^{n_0}}}} (\|Pu\|_{L^2(\Omega)} + \|u\|_{H^1(B(q_0, \rho_0))}) + C \varepsilon'^\alpha \|u\|_{C^{1,\alpha}(\bar{\Omega})}. \quad (14)$$

Since $1/\nu^{n_0} = e^{n_0 \log(1/\nu)}$, we have

$$\frac{1}{\nu^{n_0}} < e^{\log(1/\nu) \left(\frac{\log((d_0 + \rho_0)/\varepsilon')}{\log(1/\mu)} + 1 \right)} = \frac{1}{\nu} \left(\frac{d_0 + \rho_0}{\varepsilon'} \right)^{\gamma_0},$$

with $\gamma_0 = \log(1/\nu) / \log(1/\mu)$.

Furthermore, since $1/\mu^{n_0-1} < (d_0 + \rho_0)/\varepsilon'$, we have

$$\log\left(\frac{2}{\mu^{n_0-1}}\right) < \log\left(\frac{2(d_0 + \rho_0)}{\varepsilon'}\right).$$

Then,

$$\frac{e^{\frac{c}{\nu^{n_0}} \log\left(\frac{2}{\mu^{n_0-1}}\right)}}{\varepsilon'^{(\alpha+N)/\nu^{n_0}}} = e^{\frac{1}{\nu^{n_0}} \left(c \log\left(\frac{2}{\mu^{n_0-1}}\right) + (\alpha+N) \log\left(\frac{1}{\varepsilon'}\right) \right)} \leq e^{\frac{1}{\nu} \left(\frac{d_0 + \rho_0}{\varepsilon'} \right)^{\gamma_0} \left(c \log\left(\frac{2(d_0 + \rho_0)}{\varepsilon'}\right) + (\alpha+N) \log\left(\frac{1}{\varepsilon'}\right) \right)}.$$

As a result, for some new $c' > 0$, for sufficiently small ε' we have

$$\frac{e^{\frac{c}{\nu^{n_0}} \log\left(\frac{2}{\mu^{n_0-1}}\right)}}{\varepsilon'^{(\alpha+N)/\nu^{n_0}}} \leq e^{\frac{c'}{\varepsilon'^{\gamma_0}} \log\left(\frac{1}{\varepsilon'}\right)}.$$

For all $\gamma > \gamma_0$, for some new $c' > 0$, for sufficiently small ε' we have

$$\frac{e^{\frac{c}{\nu^{n_0}} \log\left(\frac{2}{\mu^{n_0-1}}\right)}}{\varepsilon'^{(\alpha+N)/\nu^{n_0}}} \leq e^{\frac{c'}{\varepsilon'^{\gamma}}}.$$

Coming back to (14), we obtain

$$S_{x_0}(u) \leq e^{c'/\varepsilon'^{\gamma}} (\|Pu\|_{L^2(\Omega)} + \|u\|_{H^1(B(q_0, \rho_0))}) + C\varepsilon'^{\alpha} \|u\|_{C^{1,\alpha}(\bar{\Omega})}.$$

By denoting $\varepsilon = \varepsilon'^{\gamma}$ for any $\gamma > \gamma_0$, for small $\varepsilon > 0$,

$$S_{x_0}(u) \leq e^{c'/\varepsilon} (\|Pu\|_{L^2(\Omega)} + \|u\|_{H^1(B(q_0, \rho_0))}) + C'\varepsilon^{\alpha/\gamma} \|u\|_{C^{1,\alpha}(\bar{\Omega})}.$$

Finally, by denoting $\kappa_0 = 1/\gamma_0$, for all $\kappa < \alpha\kappa_0$ there exists $c, \varepsilon_0 > 0$ such that for all $\varepsilon < \varepsilon_0$,

$$S_{x_0}(u) \leq e^{c/\varepsilon} (\|Pu\|_{L^2(\Omega)} + \|u\|_{H^1(B(q_0, \rho_0))}) + \varepsilon^{\kappa} \|u\|_{C^{1,\alpha}(\bar{\Omega})}.$$

By following the history of the constants c and ε_0 throughout the proof, it is readily seen that c and ε_0 do not depend on $x_0 \in \partial\Omega$. Furthermore, if we define $\omega_1 \Subset \Omega$ as the union of the balls $B(q_0, \rho_0)$ when x_0 describes $\partial\Omega$, we obtain that for all $\kappa < \alpha\kappa_0$, there exists $c, \varepsilon_0 > 0$ such that for all $\varepsilon < \varepsilon_0$, for all $u \in C^{1,\alpha}(\bar{\Omega})$ with $\Delta u \in L^2(\Omega)$,

$$\|u\|_{C^1(\partial\Omega)} \leq e^{c/\varepsilon} (\|Pu\|_{L^2(\Omega)} + \|u\|_{H^1(\omega_1)}) + \varepsilon^{\kappa} \|u\|_{C^{1,\alpha}(\bar{\Omega})}, \quad (15)$$

which is the first inequality of the proposition.

The second inequality is obtained by using the imbedding $C^{1,\alpha}(\bar{\Omega}) \rightarrow C^1(\bar{\Omega})$, for all $\alpha \in [0, 1]$. For $x \in B(q_{n_0}, \rho_{n_0})$, we replace (12) by

$$|u(x_0)|^2 \leq 2|u(x)|^2 + 2\|u\|_{C^1(\bar{\Omega})}^2 \varepsilon'^2,$$

and we use the same technique as above. The third step of the proof consists in maximizing

$$\kappa_0 = \frac{\log(1/\mu)}{\log(1/\nu)},$$

with

$$\frac{1}{\mu} = \frac{y_6 - y_2 \sin \theta}{y_6 - y_3 \sin \theta}, \quad \frac{1}{\nu} = \frac{e^{\beta(y_4^2 - y_1^2)} - 1}{e^{\beta(y_4^2 - y_3^2)} - 1}.$$

The inequality (15) holds for all $\kappa < \tilde{\kappa}_0$, with

$$\tilde{\kappa}_0 = \sup_{1 < \beta, 1 < y_1 < y_2 < y_3 < y_4 < y_6} \log\left(\frac{y_6 - y_2 \sin \theta}{y_6 - y_3 \sin \theta}\right) / \log\left(\frac{e^{\beta(y_4^2 - y_1^2)} - 1}{e^{\beta(y_4^2 - y_3^2)} - 1}\right). \quad (16)$$

Now, let specify β and the y_i as follows, for $k \in]0, 1[$ and $\delta > 0$,

$$\left\{ \begin{array}{l} \beta = \sqrt{1 + k^2}, \\ y := (1 + k^2)^{1/4}, \\ y_1 = y, \\ y_2 = y(1 + k^2\delta), \\ y_3 = y(1 + k\delta + k^2\delta), \\ y_4 = y(1 + \delta + k^2\delta), \\ y_6 = y(1 + \delta + 2k^2\delta). \end{array} \right. \quad (17)$$

A first order expansion in k around 0 for fixed δ leads to

$$\begin{aligned}\log\left(\frac{y_6 - y_2 \sin \theta}{y_6 - y_3 \sin \theta}\right) &= \frac{\delta \sin \theta}{1 + \delta - \sin \theta} k + o_\delta(k), \\ \log\left(\frac{e^{\beta(y_4^2 - y_1^2)} - 1}{e^{\beta(y_4^2 - y_3^2)} - 1}\right) &= 2\delta \frac{e^{2\delta + \delta^2}}{e^{2\delta + \delta^2} - 1} k + o_\delta(k)\end{aligned}$$

By passing to the limit $k \rightarrow 0$ and by taking the sup in δ , we obtain the following particular value $\kappa_0 \leq \tilde{\kappa}_0$:

$$\kappa_0 = \sup_{\delta > 0} \frac{1}{2} \frac{\sin \theta}{1 + \delta - \sin \theta} (1 - e^{-(2\delta + \delta^2)}),$$

and the optimization problem (6) follows by setting $x = 2\delta + \delta^2 > 0$. ■

Remark 1 : We can verify that in fact the values $\tilde{\kappa}_0$ and κ_0 , defined by (16) and (6) respectively, actually satisfy $\tilde{\kappa}_0 = \kappa_0$. First, we eliminate β in (16) simply by using the change of variables $z_i = \sqrt{\beta} y_i$ with $i = 1, \dots, 6$. We obtain

$$\tilde{\kappa}_0 = \sup_{1 < z_1 < z_2 < z_3 < z_4 < z_6} \log\left(\frac{z_6 - z_2 \sin \theta}{z_6 - z_3 \sin \theta}\right) / \log\left(\frac{e^{z_4^2 - z_1^2} - 1}{e^{z_4^2 - z_3^2} - 1}\right). \quad (18)$$

We remark that the function to maximize in (18) is an increasing function of z_1 and a decreasing function of z_6 , that is why we can consider only the asymptotic situation $z_1 \rightarrow z_2$ and $z_6 \rightarrow z_4$. In order to simplify the analysis with the remaining variables z_2, z_3, z_4 , we denote

$$z_3 - z_2 = \tilde{k} \tilde{\delta} z_2, \quad z_4 - z_2 = \tilde{\delta} z_2, \quad z_2 = \tilde{z},$$

with $\tilde{\delta} > 0$ and $\tilde{k} \in]0, 1[$. We obtain

$$\tilde{\kappa}_0 = \sup_{1 < \tilde{z}, 0 < \tilde{\delta}, 0 < \tilde{k} < 1} \log\left(\frac{1 + \tilde{\delta} - \sin \theta}{1 + \tilde{\delta} - \sin \theta - \tilde{k} \tilde{\delta} \sin \theta}\right) / \log\left(\frac{e^{(2\tilde{\delta} + \tilde{\delta}^2)\tilde{z}^2} - 1}{e^{(2(1-\tilde{k})\tilde{\delta} + (1-\tilde{k}^2)\tilde{\delta}^2)\tilde{z}^2} - 1}\right).$$

Furthermore, it is easy to prove that since $2\tilde{\delta} + \tilde{\delta}^2 > 2(1-\tilde{k})\tilde{\delta} + (1-\tilde{k}^2)\tilde{\delta}^2$, for fixed $(\tilde{k}, \tilde{\delta})$, the function to maximize is a non increasing function of $\tilde{z} > 1$, so that the maximum of the function is obtained for $\tilde{z} \rightarrow 1$, and

$$\tilde{\kappa}_0 = \sup_{0 < \tilde{\delta}, 0 < \tilde{k} < 1} \log\left(\frac{1 + \tilde{\delta} - \sin \theta}{1 + \tilde{\delta} - \sin \theta - \tilde{k} \tilde{\delta} \sin \theta}\right) / \log\left(\frac{e^{2\tilde{\delta} + \tilde{\delta}^2} - 1}{e^{2(1-\tilde{k})\tilde{\delta} + (1-\tilde{k}^2)\tilde{\delta}^2} - 1}\right).$$

We notice that for fixed $\tilde{\delta}$, the maximum of the function of two variables is obtained for $\tilde{k} \rightarrow 0$, and a first order expansion in \tilde{k} leads us to the same expression as (6), that is $\tilde{\kappa}_0 = \kappa_0$.

In order to obtain our main theorem, we recall the two following results, the first one is obtained in [12] while the second one is obtained in [4].

Proposition 2 : Let ω_0, ω_1 be two open domains such that $\omega_0, \omega_1 \Subset \Omega$. There exist $s, c, \varepsilon_0 > 0$ such that $\forall \varepsilon \in]0, \varepsilon_0[, \forall u \in H^1(\Omega, \Delta)$,

$$\|u\|_{H^1(\omega_1)} \leq \frac{c}{\varepsilon} (\|Pu\|_{L^2(\Omega)} + \|u\|_{H^1(\omega_0)}) + \varepsilon^s \|u\|_{H^1(\Omega)}.$$

Proposition 3 : Assume $\Gamma_0 \subset \partial\Omega$ is of class $C^{1,1}$ and let $x_0 \in \Gamma_0$ and $\tau > 0$ such that $\partial\Omega \cap B(x_0, \tau) \subset \Gamma_0$. There exists a neighbourhood ω_0 of x_0 , there exist $s, c, \varepsilon_0 > 0$ such that $\forall \varepsilon \in]0, \varepsilon_0[$, for all $u \in H^2(\Omega)$,

$$\|u\|_{H^1(\Omega \cap \omega_0)} \leq \frac{c}{\varepsilon} (\|Pu\|_{L^2(\Omega)} + \|u\|_{H^1(\Gamma_0)} + \|\partial_n u\|_{L^2(\Gamma_0)}) + \varepsilon^s \|u\|_{H^1(\Omega)}.$$

The inequality holds also for all $u \in C^1(\bar{\Omega})$ with $\Delta u \in L^2(\Omega)$.

We are now in a position to state the main theorem, which is a consequence of propositions 1, 2 and 3.

Theorem 1 : Let $\Omega \subset \mathbb{R}^N$ be a bounded and connected open domain with Lipschitz boundary. If the cone property is satisfied with angle $\theta \in]0, \pi/2[$, let denote $\kappa_0(\theta)$ the solution of the following maximization problem

$$\kappa_0(\theta) = \frac{1}{2} \sup_{x>0} \frac{\sin \theta (1 - e^{-x})}{\sqrt{1+x} - \sin \theta}.$$

Let Γ_0 be a $C^{1,1}$ open part of $\partial\Omega$ such that there exist $x_0 \in \Gamma_0$ and $\tau > 0$ with $\partial\Omega \cap B(x_0, \tau) \subset \Gamma_0$.

Let introduce the operator $P = -\Delta, -k.$, where k is not an eigenvalue of the Dirichlet problem for the operator $-\Delta$ in Ω .

For $\alpha \in [0, 1]$, for all $\kappa \in]0, (1 + \alpha)\kappa_0(\theta)/2[$, there exists C, δ_0 such that for all $\delta \in]0, \delta_0[$, for all functions $u \in C^{1,\alpha}(\bar{\Omega})$ such that $\Delta u \in L^2(\Omega)$ and which satisfy

$$\|u\|_{C^{1,\alpha}(\bar{\Omega})} \leq M, \quad \|Pu\|_{L^2(\Omega)} + \|u\|_{H^1(\Gamma_0)} + \|\partial_n u\|_{L^2(\Gamma_0)} \leq \delta, \quad (19)$$

where $M > 0$ is a constant, then

$$\|u\|_{H^1(\Omega)} \leq C \frac{M}{(\log(M/\delta))^\kappa}. \quad (20)$$

If we do not assume that Γ_0 is of class $C^{1,1}$, the estimate (20) holds under assumption (19) and provided we restrict to the functions u which satisfy $u|_{\Gamma_0} = 0$ and $\partial_n u|_{\Gamma_0} = 0$.

Proof : Assume first that $\alpha \in]0, 1[$. By using proposition 1, there exists a domain $\omega_1 \Subset \Omega$ such that for any $\kappa < \alpha\kappa_0(\theta)$ and any $\kappa' < \kappa_0(\theta)$, there exist $c, \varepsilon_0 > 0$ such that for all $\varepsilon < \varepsilon_0$, for all $u \in C^{1,\alpha}(\bar{\Omega})$ with $\Delta u \in L^2(\Omega)$,

$$\|u\|_{C^1(\partial\Omega)} \leq e^{c/\varepsilon} (\|Pu\|_{L^2(\Omega)} + \|u\|_{H^1(\omega_1)}) + \varepsilon^\kappa \|u\|_{C^{1,\alpha}(\bar{\Omega})},$$

and

$$\|u\|_{C^0(\partial\Omega)} \leq e^{c/\varepsilon} (\|Pu\|_{L^2(\Omega)} + \|u\|_{H^1(\omega_1)}) + \varepsilon^{\kappa'} \|u\|_{C^{1,\alpha}(\bar{\Omega})}.$$

If $u = 0$ and $\partial_n u = 0$ on Γ_0 (case 2), since $\partial\Omega \cap B(x_0, \tau) \subset \Gamma_0$, the extension \tilde{u} of u by 0 in $B(x_0, \tau)$ belongs to $H^1(\Omega \cup B(x_0, \tau), \Delta)$. By applying proposition 2 to function \tilde{u} in domain $\Omega \cup B(x_0, \tau)$ and by choosing $\omega_0 \Subset B(x_0, \tau) \cap \bar{\Omega}^c$, we obtain that for sufficiently small ε , for all $u \in C^{1,\alpha}(\bar{\Omega})$ such that $\Delta u \in L^2(\Omega)$,

$$\|u\|_{C^1(\partial\Omega)} \leq e^{c/\varepsilon} \|Pu\|_{L^2(\Omega)} + \varepsilon^\kappa \|u\|_{C^{1,\alpha}(\bar{\Omega})},$$

$$\|u\|_{C^0(\partial\Omega)} \leq e^{c/\varepsilon} \|Pu\|_{L^2(\Omega)} + \varepsilon^{\kappa'} \|u\|_{C^{1,\alpha}(\bar{\Omega})}.$$

We conclude that if moreover u satisfies assumption (19) then

$$\|u\|_{C^1(\partial\Omega)} \leq e^{c/\varepsilon}\delta + \varepsilon^\kappa M, \quad \|u\|_{C^0(\partial\Omega)} \leq e^{c/\varepsilon}\delta + \varepsilon^{\kappa'} M.$$

By using the same ε optimization procedure as in corollary 1 of [4], we obtain that for all $\kappa < \alpha\kappa_0(\theta)$ and $\kappa' < \kappa_0(\theta)$, there exists $C > 0$ such that for sufficiently small δ ,

$$\|u\|_{C^1(\partial\Omega)} \leq C \frac{M}{(\log(M/\delta))^\kappa}, \quad \|u\|_{C^0(\partial\Omega)} \leq C \frac{M}{(\log(M/\delta))^{\kappa'}}. \quad (21)$$

Since k is not an eigenvalue of the Dirichlet problem for the operator $-\Delta$ in Ω , there exists a constant $C' > 0$ such that for all $u \in H^1(\Omega, \Delta)$,

$$\|u\|_{H^1(\Omega)} \leq C' (\|Pu\|_{L^2(\Omega)} + \|u\|_{H^{1/2}(\partial\Omega)}). \quad (22)$$

With the help of an interpolation inequality, we obtain for some constant $c > 0$,

$$\|u\|_{H^{1/2}(\partial\Omega)} \leq c \|u\|_{L^2(\partial\Omega)}^{1/2} \|u\|_{H^1(\partial\Omega)}^{1/2}, \quad (23)$$

hence for some new constant c ,

$$\|u\|_{H^{1/2}(\partial\Omega)} \leq c \|u\|_{C^0(\partial\Omega)}^{1/2} \|u\|_{C^1(\partial\Omega)}^{1/2}, \quad (24)$$

and it follows from (21) that

$$\|u\|_{H^{1/2}(\partial\Omega)} \leq cC \frac{M}{(\log(M/\delta))^{(\kappa+\kappa')/2}}.$$

The result follows from (22).

If we do not assume that $u = 0$ and $\partial_n u = 0$ on Γ_0 , but if moreover Γ_0 is of class $C^{1,1}$ (case 1), then we can apply proposition 3 in addition to propositions 1 and 2, hence for all $\kappa < \alpha\kappa_0(\theta)$ and $\kappa' < \kappa_0(\theta)$, there exist $c, \varepsilon_0 > 0$ such that for all $\varepsilon < \varepsilon_0$, for all $u \in C^{1,\alpha}(\bar{\Omega})$ such that $\Delta u \in L^2(\Omega)$,

$$\|u\|_{C^1(\partial\Omega)} \leq e^{c/\varepsilon} (\|Pu\|_{L^2(\Omega)} + \|u\|_{H^1(\Gamma_0)} + \|\partial_n u\|_{L^2(\Gamma_0)}) + \varepsilon^\kappa \|u\|_{C^{1,\alpha}(\bar{\Omega})},$$

$$\|u\|_{C^0(\partial\Omega)} \leq e^{c/\varepsilon} (\|Pu\|_{L^2(\Omega)} + \|u\|_{H^1(\Gamma_0)} + \|\partial_n u\|_{L^2(\Gamma_0)}) + \varepsilon^{\kappa'} \|u\|_{C^{1,\alpha}(\bar{\Omega})}.$$

We complete the proof as in the case 2.

As concerns the case $\alpha = 0$, the result follows from (24), from the second inequality of (21), which remains true, and from the fact that $\|u\|_{C^1(\partial\Omega)} \leq M$. \blacksquare

Remark 2 : It is readily shown by analyzing the variations of the function k_θ defined on $[0, +\infty[$ by

$$k_\theta(x) = \frac{1}{2} \frac{\sin \theta (1 - e^{-x})}{\sqrt{1+x} - \sin \theta}, \quad (25)$$

that the maximization problem (6) is well-posed. In particular, the argument x that maximizes the function is unique. In figure 2, the graph of function k_θ is plotted for increasing values of θ , and the values of function κ_0 are plotted for

all values of $\theta \in [0, \pi/2]$. The function κ_0 is increasing on the segment $[0, \pi/2]$, with $\kappa_0(0) = 0$ and $\kappa_0(\pi/2) = 1$.

Remark 3 : The fact that $\kappa_0(0) = 0$ indicates that when $\theta \rightarrow 0$, which means that the domain Ω has a cusp, the logarithmic stability does not hold any more. This is consistent with the result obtained in [2] when the domain is not Lipschitz, then a logarithmic-logarithmic estimate was established.

Remark 4 : The fact that $\kappa_0(\pi/2) = 1$ implies that for domains of class C^1 , theorem 1 holds for all $\kappa < (1 + \alpha)/2$. Hence, in the case of functions u in $C^{1,1}(\bar{\Omega}) \subset H^2(\Omega)$ ($\alpha = 1$), theorem 1 extends the result of corollary 1 in [4], which was satisfied for domains of class $C^{1,1}$, to domains of class C^1 , provided either Γ_0 is of class $C^{1,1}$ or we restrict to the functions u which satisfy $u = 0$ and $\partial_n u = 0$ on Γ_0 . It is also interesting to note that in $2D$, if Ω has only reentrant corners, then the cone property is satisfied for any $\theta \in]0, \pi/2[$, and theorem 1 holds for all $\kappa < 1$. Hence, the corners of angle smaller than π deteriorate the exponent of the logarithmic stability, while those of angle larger than π do not. A similar remark can be done in $3D$.

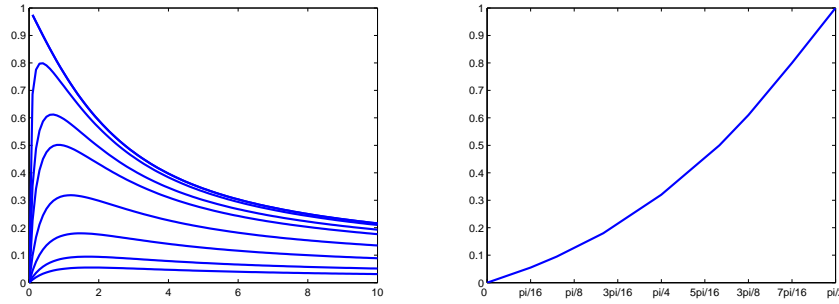

Figure 2: Left : graph of function k_θ for increasing values of $\theta : \pi/16, \pi/10, \pi/6, \pi/4, \pi/3, 3\pi/8, 7\pi/16, \pi/2$. Right : function $\kappa_0(\theta)$

Remark 5 : The obtained function (25) is strongly dependent on the choice of the function $\psi(x) = -|x - q|^2$ which was used in the exponential weight $\phi = e^{\alpha\psi}$ of our Carleman estimate (3). Besides, the values of $\kappa_0(\theta)$ induced by this choice and given by (6) are not necessarily optimal, except for $\theta = \pi/2$, for which we have proved in [4] that $\kappa_0(\pi/2) = 1$ is optimal. By testing other types of function ψ , in particular $\psi(x) = -|x - q|^\beta$ with other values of $\beta > 0$ and $\psi(x) = -\log|x - q|$, we have found other functions κ_0 , but taking lower values.

Remark 6 : From the proof of theorem 1, we obtain the following corollary concerning the data completion problem. This problem consists, for a function u that solves $Pu = 0$ in Ω in the sense of distributions, to compute with the help of the values of u and $\partial_n u$ on Γ_0 , the values of u and $\partial_n u$ on the complementary part Γ_1 . If $u \in C^{1,\alpha}(\bar{\Omega})$, $\alpha \in]0, 1]$, solves $Pu = 0$ in Ω and satisfies $\|u\|_{C^{1,\alpha}(\bar{\Omega})} \leq M$ and $\|u\|_{C^1(\bar{\Gamma}_0)} \leq \delta$, then for all $\kappa < \alpha\kappa_0(\theta)$, there exists $C, \delta_0 > 0$ such that for $\delta < \delta_0$, $\|u\|_{C^1(\bar{\Gamma}_1)} \leq CM/(\log(M/\delta))^\kappa$.

In a view to derive a convergence rate of the method of quasi-reversibility, we now study the case of functions that are $H^2(\Omega)$ for $N = 2$ and $N = 3$. We obtain the following theorem.

Theorem 2 : *We define the sets Ω , Γ_0 and the operator P exactly as in the statement of theorem 1.*

In the case $N = 2$ (resp. $N = 3$), for all $\kappa \in]0, \kappa_0(\theta)/2[$ (resp. $\kappa \in]0, \kappa_0(\theta)/4[$), there exists C, δ_0 such that for all $\delta \in]0, \delta_0[$, for all functions $u \in H^2(\Omega)$ which satisfy

$$\|u\|_{H^2(\Omega)} \leq M, \quad \|Pu\|_{L^2(\Omega)} + \|u\|_{H^1(\Gamma_0)} + \|\partial_n u\|_{L^2(\Gamma_0)} \leq \delta, \quad (26)$$

where $M > 0$ is a constant, then

$$\|u\|_{H^1(\Omega)} \leq C \frac{M}{(\log(M/\delta))^\kappa}. \quad (27)$$

If we do not assume that Γ_0 is of class $C^{1,1}$, the estimate (27) holds under assumption (26) and provided we restrict to the functions u which satisfy $u|_{\Gamma_0} = 0$ and $\partial_n u|_{\Gamma_0} = 0$.

Proof : By classical imbeddings for Sobolev Spaces (see for example [1], p. 108), we have that for $N = 2$, $H^2(\Omega) \rightarrow C^{0,\alpha}(\overline{\Omega})$, for all $\alpha \in [0, 1[$, and for $N = 3$, $H^2(\Omega) \rightarrow C^{0,1/2}(\overline{\Omega})$.

Then the proof is very similar to the proof of theorem 1. For all $\kappa < \kappa_0(\theta)$ in the case $N = 2$ (resp. for all $\kappa < \kappa_0(\theta)/2$ in the case $N = 3$), there exists $c > 0$ such that for sufficiently small ε , for all $u \in H^2(\Omega)$,

$$\|u\|_{C^0(\partial\Omega)} \leq e^{c/\varepsilon} (\|Pu\|_{L^2(\Omega)} + \|u\|_{H^1(\omega_1)}) + \varepsilon^\kappa \|u\|_{H^2(\Omega)},$$

and then by using propositions 2 and 3,

$$\|u\|_{C^0(\partial\Omega)} \leq e^{c/\varepsilon} (\|Pu\|_{L^2(\Omega)} + \|u\|_{H^1(\Gamma_0)} + \|\partial_n u\|_{L^2(\Gamma_0)}) + \varepsilon^\kappa \|u\|_{H^2(\Omega)}.$$

Then assumption (26) implies

$$\|u\|_{C^0(\partial\Omega)} \leq e^{c/\varepsilon} \delta + \varepsilon^\kappa M.$$

By using the same ε optimization procedure as in corollary 1 of [4], we obtain that there exists $C > 0$ such that for sufficiently small δ ,

$$\|u\|_{C^0(\partial\Omega)} \leq C \frac{M}{(\log(M/\delta))^\kappa}.$$

Combining (22) and (23), we obtain

$$\|u\|_{H^1(\Omega)} \leq C (\|Pu\|_{L^2(\Omega)} + \|u\|_{C^0(\partial\Omega)}^{1/2} \|u\|_{H^1(\partial\Omega)}^{1/2}).$$

By using a classical trace inequality, we obtain

$$\|u\|_{H^1(\Omega)} \leq C (\|Pu\|_{L^2(\Omega)} + \|u\|_{C^0(\partial\Omega)}^{1/2} \|u\|_{H^2(\Omega)}^{1/2}),$$

which completes the proof . ■

4 Application to the method of quasi-reversibility

In this section, we use the stability estimates obtained in previous section to derive a convergence rate for the quasi-reversibility method, and therefore to complete the results already obtained in [4, 8]. The method of quasi-reversibility, first introduced in [10], enables one to regularize the ill-posed elliptic Cauchy problems.

Specifically, we consider a bounded and connected open domain $\Omega \subset \mathbb{R}^N$ with Lipschitz boundary and an open part Γ_0 of $\partial\Omega$ such that there exist $x_0 \in \Gamma_0$ and $\tau > 0$ with $\partial\Omega \cap B(x_0, \tau) \subset \Gamma_0$.

Now we assume that $u \in H^2(\Omega)$ solves the ill-posed Cauchy problem with data $(g_0, g_1) \in H^1(\Gamma_0) \times L^2(\Gamma_0)$:

$$\begin{cases} Pu = 0 & \text{in } \Omega \\ u|_{\Gamma_0} = g_0 \\ \partial_n u|_{\Gamma_0} = g_1. \end{cases} \quad (28)$$

In order to solve the Cauchy problem with these uncorrupted data (g_0, g_1) , for $\alpha > 0$ we consider the formulation of quasi-reversibility, written in the following weak form : find $u_\alpha \in H^2(\Omega)$ such that $\forall v \in H^2(\Omega)$, $v|_{\Gamma_0} = \partial_n v|_{\Gamma_0} = 0$,

$$\begin{cases} (Pu_\alpha, Pv)_{L^2(\Omega)} + \alpha(u_\alpha, v)_{H^2(\Omega)} = 0 \\ u_\alpha|_{\Gamma_0} = g_0 \\ \partial_n u_\alpha|_{\Gamma_0} = g_1. \end{cases} \quad (29)$$

Using Lax-Milgram theorem and introducing the solution u to the system (28), we easily prove that formulation (29) is well-posed. On the other hand, it follows from (28) and (29) that there exist constants $C_1, C_2 > 0$ such that

$$\|u_\alpha - u\|_{H^2(\Omega)} \leq C_1, \quad \|P(u_\alpha - u)\|_{L^2(\Omega)} \leq C_2\sqrt{\alpha}. \quad (30)$$

Using (30) and theorem 2 in the case 2 for function $u_\alpha - u \in H^2(\Omega)$, we obtain the following convergence rate : there exists $C > 0$ for all $\kappa \in]0, \kappa_0(\theta)/2[$ (resp. $\kappa \in]0, \kappa_0(\theta)/4[$) for $N = 2$ (resp. for $N = 3$), such that for sufficiently small $\alpha > 0$,

$$\|u_\alpha - u\|_{H^1(\Omega)} \leq C \frac{1}{(\log(1/\alpha))^\kappa}. \quad (31)$$

Note that if additionally we assume that $u_\alpha - u \in H^3(\Omega)$ and

$$\|u_\alpha - u\|_{H^3(\Omega)} \leq C_1, \quad (32)$$

with the help of the imbeddings $H^3(\Omega) \rightarrow C^{1,\lambda}(\overline{\Omega})$ for all $\lambda \in [0, 1[$ and $H^3(\Omega) \rightarrow C^{1,1/2}(\overline{\Omega})$, the estimate (31) holds for all $\kappa \in]0, \kappa_0(\theta)[$ (resp. $\kappa \in]0, 3\kappa_0(\theta)/4[$) for $N = 2$ (resp. for $N = 3$).

In order to test the optimality of (31), we introduce a discretized weak formulation of quasi-reversibility, which is associated to the continuous weak formulation (29). In this view, we consider the particular case $N = 2$, $P = -\Delta$, and Ω is a polygonal domain. We use the so-called Fraeijs de Veubeke's finite element (F.V.1), introduced in [7] and analyzed in [9]. This nonconforming finite element, initially designed to solve plate bending problems, can be also used to solve the quasi-reversibility formulation (29). In the present paper, we briefly

describe such element, but a comprehensive analysis of the discretized formulation is postponed in a future paper.

We consider a regular triangulation \mathcal{T}_h of $\overline{\Omega}$ (see [5] for definition) such that the diameter of each triangle $K \in \mathcal{T}_h$ is bounded by h . The set $\overline{\Gamma}_0$ consists of the union of the edges of some triangles $K \in \mathcal{T}_h$, and the complementary part of the boundary $\partial\Omega$ is denoted Γ_1 . We denote W_h , the set of functions $w_h \in L^2(\Omega)$ such that for all $K \in \mathcal{T}_h$, $w_h|_K$ belongs to the space of shape functions P_K in K (see [9] for definition of P_K), and such that the degrees of freedom coincide, that is : the values of the function at the vertices, the values at the mid-points of the edges of the element, and the mean values of the normal derivative along each edge.

Then, we define $V_{h,0}$ as the subset of functions of W_h for which the degrees of freedom on the edges contained in $\overline{\Gamma}_0$ vanish, and V_h as the subset of functions of W_h for which the degrees of freedom on the edges contained in $\overline{\Gamma}_0$ coincide with the corresponding values obtained with data g_0 and g_1 .

For $\alpha > 0$, we consider the discretized formulation of quasi-reversibility, written in the following weak form : find $u_{h,\alpha} \in V_h$, such that for all $w_h \in V_{h,0}$,

$$\sum_{K \in \mathcal{T}_h} \{(\Delta u_{h,\alpha}, \Delta w_h)_{L^2(K)} + \alpha(u_{h,\alpha}, w_h)_{H^2(K)}\} = 0. \quad (33)$$

To analyze convergence when h tends to 0, we introduce the norms $\|\cdot\|_{2,h}$ and $\|\cdot\|_{1,h}$, which are defined, for $w_h \in W_h$, by

$$\|w_h\|_{2,h}^2 = \sum_{K \in \mathcal{T}_h} \|w_h\|_{H^2(K)}^2, \quad \|w_h\|_{1,h}^2 = \sum_{K \in \mathcal{T}_h} \|w_h\|_{H^1(K)}^2.$$

By adapting to our case the arguments used in [3] with the Morley's finite element for the plate bending problem, we prove that provided u_α is smooth enough, then for fixed α , $\|u_{h,\alpha} - \pi_h u_\alpha\|_{2,h} \rightarrow 0$ like h when $h \rightarrow 0$, where $\pi_h u_\alpha$ is the interpolate of u_α in W_h . By using the estimate (31), we conclude that for small fixed h , we have the approximate convergence rate in α :

$$\|u_{h,\alpha} - \pi_h u\|_{1,h} \lesssim C \frac{1}{(\log(1/\alpha))^\kappa}. \quad (34)$$

This is the reason why we hope to capture the logarithmic exponent κ by using a refined mesh.

In our numerical experiments, we solve the problem (33) with data $g_0 = u|_{\Gamma_0}$ and $g_1 = \partial_n u|_{\Gamma_0}$ for different harmonic functions u defined by $u_n = \mathcal{R}e(z^n)$, with $z = x+iy$ and $n = 1, 2, \dots$. For increasing values of n , the corresponding function u_n is more and more oscillating, which is likely to deteriorate the convergence rate in α for fixed h . We stop increasing n as soon as $\|u_{h,\alpha} - \pi_h u\|_{1,h}$ becomes bigger than $0.1 \|\pi_h u\|_{1,h}$, that is when h is not sufficiently small to enable the regularization process in α . In order to test different angles θ , Ω is either a triangle of smaller angle $2\theta = \pi/8$, $2\theta = \pi/5$, $2\theta = \pi/3$, or a pentagon of smaller angle $2\theta = \pi/2$ (see figure 3). The set $\overline{\Gamma}_0$ covers 60% of the total boundary $\partial\Omega$ in all cases. The size of the mesh h is fixed to $1/150$, which has to be compared to the edge of length 1 such as indicated on figure 3. The figure 4 represents the function $\pi_h u$ for $u = \mathcal{R}e(z^3)$ in the case $2\theta = \pi/3$, as well as the function $u_{h,\alpha} - \pi_h u$, where $u_{h,\alpha}$ is the solution of (33) for $\alpha = 10^{-2}$, $\alpha = 10^{-4}$

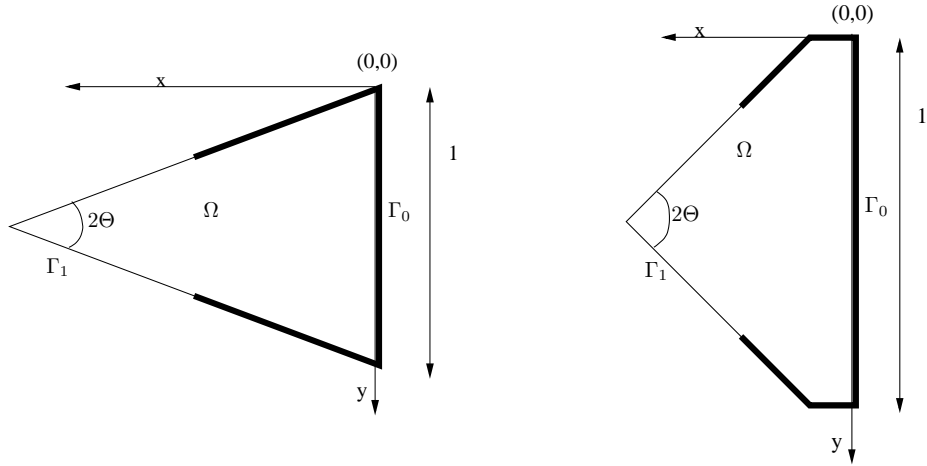
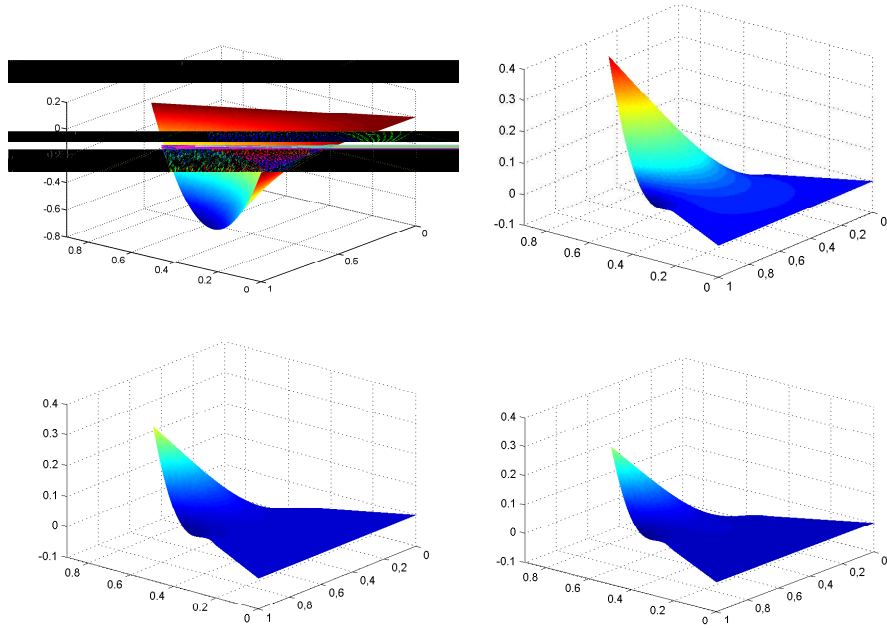
 Figure 3: Domains Ω under consideration

 Figure 4: Exact solution $\mathcal{R}e(z^3)$ for angle $2\theta = \pi/3$, discrepancy between the retrieved and the exact solution for $\alpha = 10^{-2}$, $\alpha = 10^{-4}$ and $\alpha = 10^{-6}$

and $\alpha = 10^{-6}$. In order to capture the dependence of $\|u_{h,\alpha} - \pi_h u\|_{1,h}$ on α given by (34), we plot

$$\log(\|u_{h,\alpha} - \pi_h u\|_{1,h}) = F(\log(\log(1/\alpha)))$$

for functions $u = u_n$ which correspond to increasing values of n . The first important result is that the graph of the function F we obtain is actually a line of negative slope, which is an experimental confirmation of the logarithmic stability

we have established. Furthermore, we remark that this slope is decreasing with n , as predicted above. The figure 5 clearly illustrates this fact, in the case $2\theta = \pi/3$, for $n = 2, 3, 5$. The second and main important result is the way the slope depends on the smaller angle 2θ of the polygon. As can be seen on figure 6, the slope of F is increasing as a function of θ for fixed n , as predicted by (6). More precisely, we observe that for increasing values of n , the slope tends asymptotically to some value which is approximately the value $\kappa_0(\theta)$ given by (6), in particular for small values of θ . Hence, it turns out that our estimate (31) for any $\kappa < \kappa_0(\theta)$ (with the additional regularity assumption (32)), which is not proved to be optimal, seems not far away from optimality.

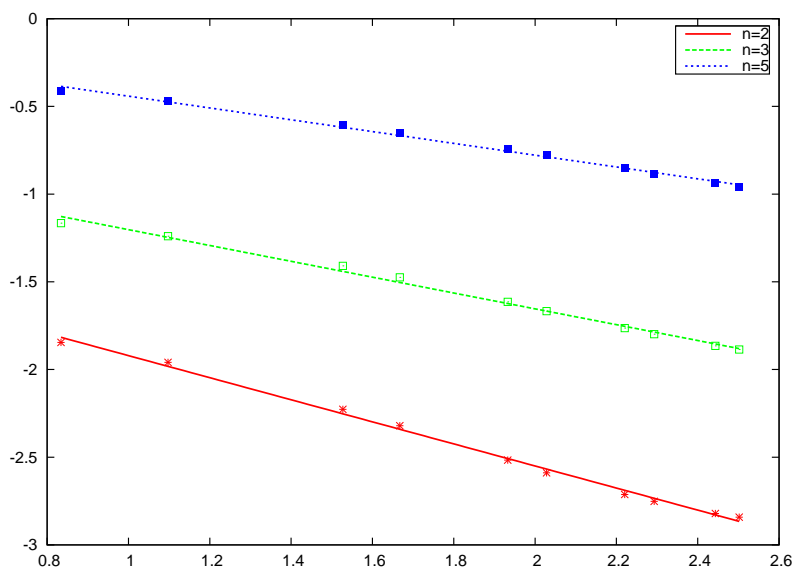

Figure 5: Function F for $2\theta = \pi/3$ and $n = 2, 3, 5$

References

- [1] R. ADAMS. *Sobolev spaces*. Academic Press, 1975.
- [2] G. ALESSANDRINI, E. BERETTA, E. ROSSET, S. VESSELLA. Optimal stability for inverse elliptic boundary value problems with unknown boundaries. *Annali della Scuola Normale Superiore di Pisa*, 29(4), 755–806, 2000.
- [3] C. BERNARDI, Y. MADAY, F. RAPETTI. *Discrétisations variationnelles de problèmes aux limites elliptiques*. Springer-Verlag Berlin, 2004.
- [4] L. BOURGEOIS. Conditional stability for ill-posed elliptic Cauchy problems : the case of $C^{1,1}$ domains (part I). *Rapport INRIA n6585*, 2008.
- [5] P.-G. CIARLET. *The Finite Element Method for Elliptic Problems*. North Holland, Amsterdam, 1978.

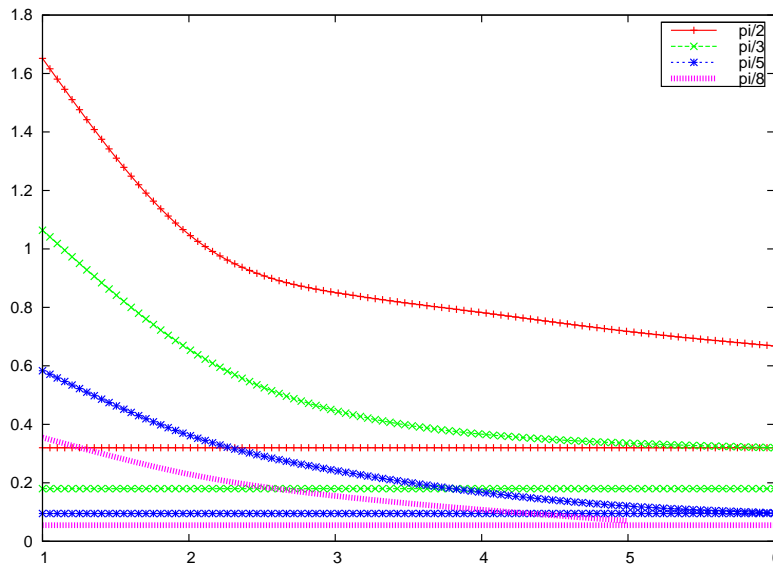

Figure 6: Slope of the linear function F as a function of n , for $2\theta = \pi/8, \pi/5, \pi/3, \pi/2$, compared to the theoretical slope $\kappa_0(\theta)$

- [6] C. FABRE, G. LEBEAU. Prolongement unique des solutions de l'équation de Stokes. *Communication in Partial Differential Equations*, 21, 573–596, 1996.
- [7] B. FRAEIJIS DE VEUBEKE. Variational principles and the patch test. *Internat. J. Numer. Methods Engrg.*, 8, 783–801, 1974.
- [8] M. V. KLIBANOV, A. A. TIMONOV. *Carleman Estimates for Coefficient Inverse Problems and Numerical Applications*. VSP, 2004.
- [9] P. LASCAUX, P. LESAIN. Some nonconforming finite elements for the plate bending problem. *R.A.I.R.O.*, 1975.
- [10] R. LATTÈS, J.-L. LIONS. *Méthode de quasi-réversibilité et applications*. Dunod, 1967.
- [11] G. LEBEAU, L. ROBBIANO. Contrôle exact de l'équation de la chaleur. *Communication in Partial Differential Equations*, 20, 335–356, 1995.
- [12] K.-D. PHUNG. Remarques sur l'observabilité pour l'équation de Laplace. *ESAIM : Control, Optimisation and Calculus of Variations*, 9, 621–635, 2003.
- [13] E. SINCICH. *Stability and reconstruction for the determination of boundary terms by a single measurement*, Thesis. SISSA/ISAS, Trieste, Italy, 2005.

Contents

1	Introduction	3
2	Some preliminary results	5
3	The main theorem	9
4	Application to the method of quasi-reversibility	21



Centre de recherche INRIA Paris – Rocquencourt

Domaine de Voluceau - Rocquencourt - BP 105 - 78153 Le Chesnay Cedex (France)

Centre de recherche INRIA Bordeaux – Sud Ouest : Domaine Universitaire - 351, cours de la Libération - 33405 Talence Cedex

Centre de recherche INRIA Grenoble – Rhône-Alpes : 655, avenue de l'Europe - 38334 Montbonnot Saint-Ismier

Centre de recherche INRIA Lille – Nord Europe : Parc Scientifique de la Haute Borne - 40, avenue Halley - 59650 Villeneuve d'Ascq

Centre de recherche INRIA Nancy – Grand Est : LORIA, Technopôle de Nancy-Brabois - Campus scientifique

615, rue du Jardin Botanique - BP 101 - 54602 Villers-lès-Nancy Cedex

Centre de recherche INRIA Rennes – Bretagne Atlantique : IRISA, Campus universitaire de Beaulieu - 35042 Rennes Cedex

Centre de recherche INRIA Saclay – Île-de-France : Parc Orsay Université - ZAC des Vignes : 4, rue Jacques Monod - 91893 Orsay Cedex

Centre de recherche INRIA Sophia Antipolis – Méditerranée : 2004, route des Lucioles - BP 93 - 06902 Sophia Antipolis Cedex

Éditeur

INRIA - Domaine de Voluceau - Rocquencourt, BP 105 - 78153 Le Chesnay Cedex (France)

ISSN 0249-6399